



RedEdge-MX™ & Altum™ DJI Matrice 100/600 Quick Mount INTEGRATION GUIDE



Table of Contents

Thank you for your purchase!	2
What's inside?	2
What's Required?	3
Let's get started!	3
Attaching DLS 2 mast assembly	3
RedEdge-MX Instructions	5
Attaching the RedEdge-MX and the Mount	5
Attaching the RedEdge-MX and DLS 2 to the Matrice	6
Altum Instructions	7
Attaching the Altum and the Mount	7
Attaching the Altum and DLS 2 to the Matrice	8
Support	10

Thank you for your purchase!

These instructions show how to integrate the MicaSense RedEdge-MX and/or Altum with a DJI Matrice 100/600. It covers attaching mounting brackets included in the kit, powering the camera from the host system, and placement of the Downwelling Light Sensor (DLS 2) unit.



Warning: This kit is not intended for any other RedEdge models other than the RedEdge-M/MX and Altum. Damage will occur if any other RedEdge model is connected.

What's inside?

1. Quick Mount Adapter (Qty 1)
2. 6 Pin Cable (Qty 1)
3. Sensor Mounting Plate (Qty 1)
4. Go-Pro Mount Adapter (Qty 1)
5. M 3 X 0.5, 8 mm Screws (Qty 4)
6. M 2 X 0.4, 6 mm Screws (Qty 2)
7. M 2 X 0.4, 8 mm Screws (Qty 2)
8. M 2.5 X 0.45, 4 mm Screws (Qty 2)
9. Alcohol Wipe (Qty 1)
10. Zip Ties (Qty 4)
11. Double Sided Tape (Qty 5)
12. DLS2 Mounting Disc (Qty 1)
13. DLS2 Mast kit (Qty 1)
14. Connector Board (Qty 1)



Images shown are not to scale

What's Required?

- #1 Phillips Screwdriver
- Cutting tool - such as scissors or diagonal cutter
- 1.5 mm hex wrench
- 2 mm hex wrench

Let's get started!



Warning: Installation of this kit into a drone should be done by an experienced person, in adherence with all recommendations and guidelines of the Matrice manufacturer. Before assembling this kit, ensure the Matrice 100/600 is not powered, has the battery removed, and the rotor blades removed. Failure to follow these instructions can result in injury and/or damage to the Matrice, RedEdge-MX, or Altum.

Attaching DLS 2 mast assembly

1. Locate and remove the DJI mast kit from its packaging.
2. There are three carbon rod sizes. Choose the longest and insert it into the base mount.
3. Secure the base mount with the included M2 screw.
4. Place the top cap on the other side of the carbon rod.
5. Secure the top cap on the rod by screwing the M2 screw.
6. Screw in the base of the mast assembly into the aircraft frame using the provided M2.5 screws and mating cap.
7. Secure the DLS2 mounting disc to the mast using the provided M2.5 x 4mm screws.
8. Mount the DLS2 to the DLS2 mounting disc using the provided M2 x 6mm screws.
9. Ensure the DLS 2 connector is oriented toward the front of the drone.
10. Use zip ties to secure any loose wires.



DLS2 Mounted on Matrice 100



Assembled DLS2 Mast Mounting Plate



Warning: Failure to properly secure loose wires may lead to interference with the aircraft propellers. This may damage the Matrice, RedEdge-MX/Altum, or both.

RedEdge-MX Instructions

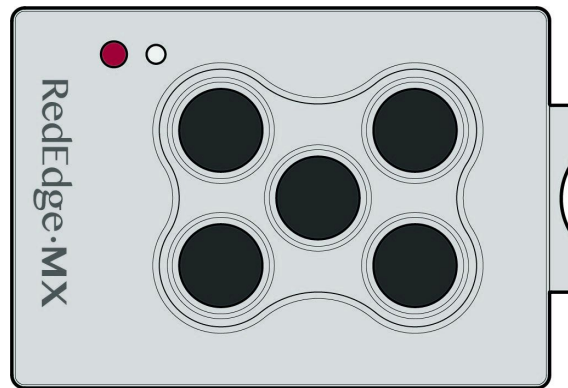

Attaching the RedEdge-MX and the Mount

1. Locate the four M3 x 8 mm flat-head screws and sensor mounting plate.
2. Peel off the brown protective paper from the sensor mounting plate.
3. Using the countersink screw holes, attach the mount to the back of the RedEdge-MX.
4. Locate the two M2 x 8 mm screws and the Go-Pro mount adapter.
5. Attach the Go-Pro mount adapter to the sensor mounting plate.
6. Locate the Quick Mount adapter and remove the thumbscrew.
7. Attach the Go-Pro mount adapter of the assembled sensor mounting plate to the Quick mount adapter and secure it with the thumbscrew.
8. Connect the Quick Mount cable to the RedEdge-MX "PWR/TRG" port.

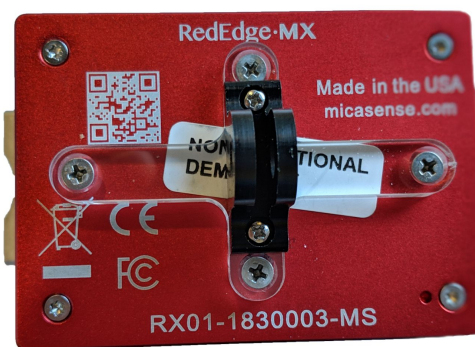

Mounting Bracket attached to RedEdge-MX



Fully connected Quick Mount

Attaching the RedEdge-MX and DLS 2 to the Matrice

Once assembled, the Quick Mount can quickly and easily be installed or removed from the Matrice. Power is provided by the Matrice via the Quick Mount.

1. Attach the assembled Quick Mount (with connected RedEdge-MX) to the Matrice using the DJI lock mechanism on the Matrice.
2. Plug the DLS 2 cable from the DLS 2 port to the connector board.
3. Using the provided shorter 6-pin cable, connect the RedEdge-MX "DLS" port to the connector board.

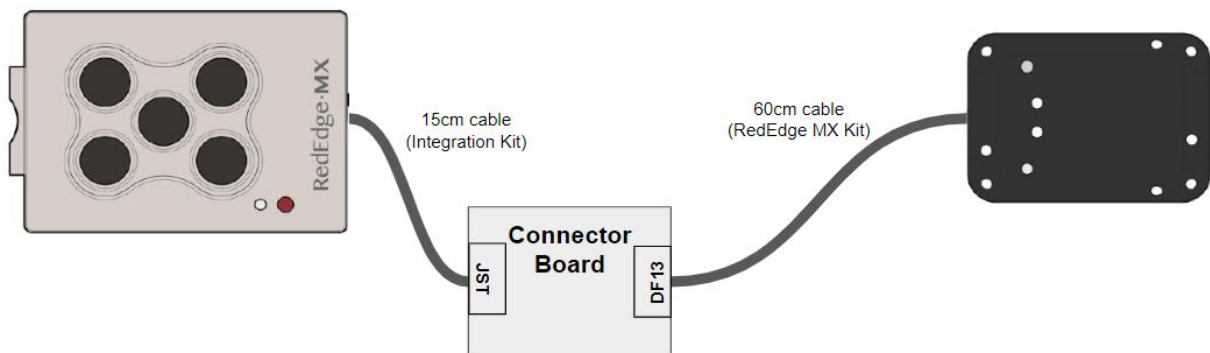

Diagram: RedEdge-MX to Connector Board to DLS 2

4. Secure the connector board using the double sided tape in a safe location.
5. Angle the camera so that, while flying forward, it will point nadir (straight down). The forward-tilt angle can vary by aircraft, but it is typically 8° to 12°.
6. Use zip ties to secure any loose wires.



Quick Mount on Matrice 100



Warning: Failure to properly secure loose wires may lead to interference with the aircraft propellers. This may damage the Matrice, RedEdge-MX/Altum, or both.

Altum Instructions

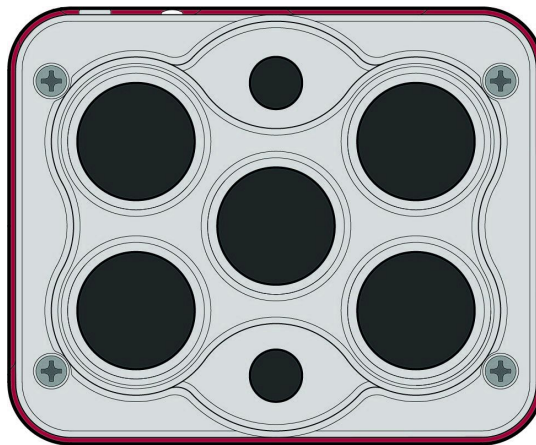

Attaching the Altum and the Mount

1. Locate the four M3 x 8 mm flat-head screws and sensor mounting plate.
2. Peel off the brown protective paper from the sensor mounting plate.
3. Using the countersink screw holes, attach the mount to the back of the Altum.
4. Locate the two M2 x 8 mm screws and the Go-Pro mount adapter.
5. Attach the Go-Pro mount adapter to the sensor mounting plate.
6. Locate the Quick Connect mount and remove the thumbscrew.

- Attach the Go-Pro mount adapter of the assembled sensor mounting plate to the Quick mount adapter and secure it with the thumbscrew.
- Connect the Quick Mount cable to the Altum wire harness.



Fully connected QuickMount

Attaching the Altum and DLS 2 to the Matrice

Once assembled, the Quick Mount can quickly and easily be installed or removed from the Matrice. Power is provided by the Matrice via the Quick Mount.

- Attach the assembled Quick Mount (with connected Altum) to the Matrice using the DJI lock mechanism on the Matrice.
- Plug the DLS 2 cable from the DLS 2 port to the connector board.
- Using the provided shorter 6-pin cable, connect the Altum "DLS" wire harness to the connector board.

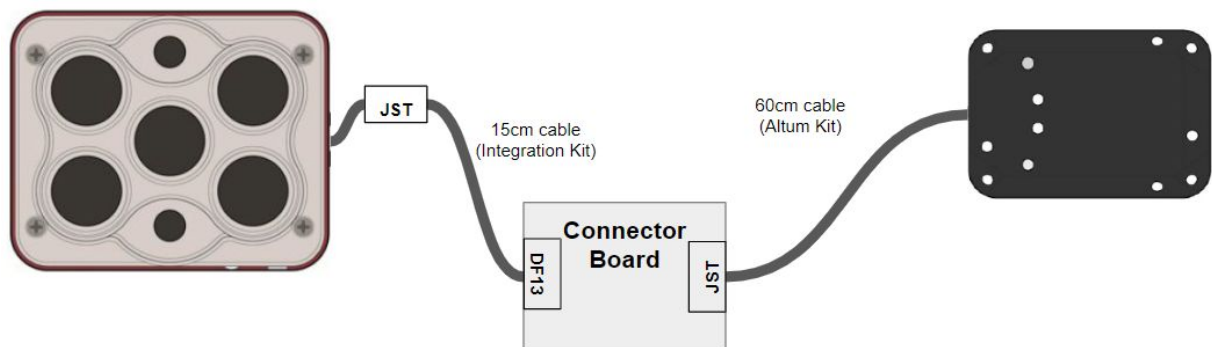

Diagram: Altum to Connector Board to DLS 2

- Secure the connector board using the double sided tape in a safe location.

5. Angle the camera so that, while flying forward, it will point nadir (straight down). The forward-tilt angle can vary by aircraft, but it is typically 8° to 12°.
6. Use zip ties to secure loose wires to prevent entanglement.



Warning: Failure to properly secure loose wires may lead to interference with the aircraft propellers. This may damage the Matrice, RedEdge-MX/Altum, or both.

Support

For other RedEdge-MX or Altum associated integration guides, please visit our Knowledge Base at support.micasense.com

For additional questions, please contact support@micasense.com

MicaSense RedEdge-MX & Altum Quick Mount for DJI Matrice 100/600 Instructions.

The contents of this manual are subject to change without notice.

MicaSense, Inc. assumes no liability for incidental or consequential damages arising from the use of this product, and any claims by a third party.

Copying of the contents of this manual, in whole or in part, as well as the scanner applications is prohibited under the copyright law.

DISCLAIMER OF WARRANTIES AND LIMITATION OF LIABILITY

MICASENSE MAKES NO REPRESENTATION OR WARRANTY, EXPRESS OR IMPLIED, WITH RESPECT TO MICASENSE ACCESSORIES. MICASENSE DISCLAIMS ANY LIABILITY FOR INDIRECT, CONSEQUENTIAL, PUNITIVE, OR SPECIAL DAMAGES, INCLUDING WITHOUT LIMITATION DAMAGES FOR LOST DATA, LOST REVENUE, LOST PROFITS, OR REPLACEMENT PRODUCT COSTS ARISING OUT OF THE PURCHASE, USE, OR PERFORMANCE OF THE MICASENSE ACCESSORIES, UNDER ANY THEORY OF LIABILITY, EVEN IF MICASENSE HAS BEEN ADVISED OF THE POSSIBILITY OF SUCH DAMAGES. MICASENSE DISCLAIMS ANY IMPLIED WARRANTY OF MERCHANTABILITY OR FITNESS FOR A PARTICULAR PURPOSE, AND DISCLAIMS ANY IMPLIED WARRANTY ARISING FROM A COURSE OF PERFORMANCE, DEALING, USAGE, OR TRADE PRACTICE. THE PRICE OF PRODUCTS DISTRIBUTED BY MICASENSE OR ITS AUTHORIZED DEALERS REFLECTS THE ALLOCATION OF RISK ARISING FROM THE WARRANTY EXCLUSIONS AND THIS DISCLAIMER AND LIMITATION OF LIABILITY.

It's simple to plan a successful mission



FLY

The MicaSense sensors low weight, low power requirements, and ability to capture RGB and narrowband spectral bands simultaneously means you can gather the data you need in fewer flights. Have multiple UAVs? MicaSense sensors quickly integrate with many different drone platforms.



PROCESS

With MicaSense sensors, you own your data. You're not limited to a particular processing platform. You can choose whichever platform is best for you, your customer, or your project.



ANYWHERE

We know you need tools you can rely on. That's why we built the sensors we wanted in the field—predictable, tough, and reliable—so you can gather the data you need when you need it.



ANALYZE

RedEdge-MX and Altum have five bands—blue, green, red, red edge, and near-infrared—that our research showed were optimal for sensing crop health. It simply shows you more. And with MicaSense Atlas, you can see many different analytical layers in one easy to use interface, and compare these outputs across time.

To learn more about Atlas or to start a free trial, please visit micasense.com/atlas



SIGN UP

Visit atlas.micasense.com to create your free MicaSense ATLAS account.



DOWNLOAD

Download RedEdge-M user manuals, integration guides and support resources via your ATLAS account.



CONTACT

Support@micasense.com US based MicaSense support is here to help.



Located in Seattle, Washington, MicaSense delivers integrated solutions for data gathering, processing, and analytics across the global agriculture market. With decades of expertise in widely varied UAV applications, the MicaSense team is redefining remote sensing technology and pioneering new ways to collect and analyze information.

MicaSense RedEdge-MX/Altum QuickConnect DJI Matrice 100/600 Integration Guide Rev 02 –
July 2019
P/N: 805-00025

Revision History

Revision	Description	Date
01	Initial Release	04 Dec 2018
02	Kit content updated	29 Jul 2019