

## RedEdge-M™ / DJI Matrice 100 INTEGRATION GUIDE

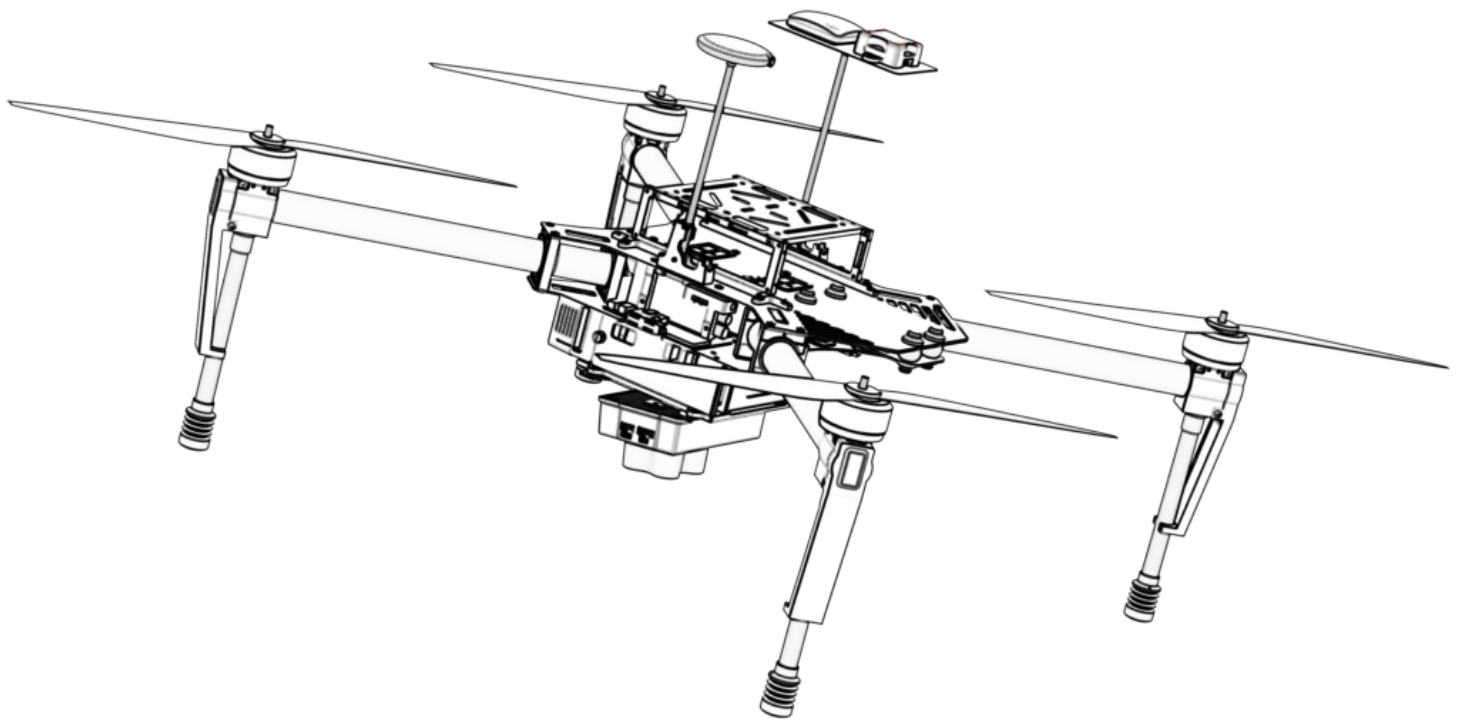

# Table of Contents

<b>Thank you for your purchase!</b> .....	1
<b>What's inside?</b> .....	1
<b>What's Required?</b> .....	2
<b>Let's get started!</b> .....	2
Attaching the RedEdge and the RedEdge Mount.....	2
Attaching DLS/GPS mast assembly.....	3
Powering the RedEdge-M.....	5
Support.....	5

# Thank you for your purchase!

These instructions show how to integrate the MicaSense RedEdge-M with a DJI Matrice 100. This will cover attaching mounting brackets included in the kit, powering the camera from the host system, and placement of the Downwelling Light Sensor (DLS) and GPS puck.

## What's inside?

- |   |                                   |
|---|-----------------------------------|
| <b>1</b> Battery Eliminator Circuit (BEC) (Qty 1) | <b>7</b> M3 x 5mm screw (QTY 4)   |
| <b>2</b> RedEdge-M Mount (Qty 1)                  | <b>8</b> 4" nylon zip tie (Qty 8) |
| <b>3</b> DJI mast kit (Qty 1)                     | <b>9</b> VHB tape squares (Qty 5) |
| <b>4</b> GPS-DLS mounting plate (Qty 1)           | <b>10</b> Alcohol wipe (Qty 1)    |
| <b>5</b> M3 x 6mm machine screw (Qty 4)           | <b>11</b> M3 lock washer (QTY 8)  |
| <b>6</b> M3 Flat washer (Qty 8)                   |                                   |

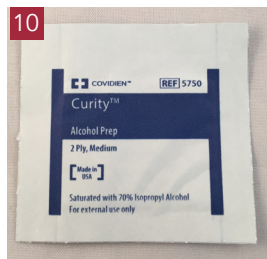
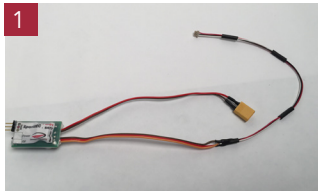

NOTE: Images are not shown to scale

# What's Required?

- ✓ #1 Phillips Screwdriver
- ✓ Cutting tool - such as scissors or diagonal cutter
- ✓ 1.5mm hex wrench
- ✓ 2mm hex wrench

## Let's get started!



Warning: Installation of this kit into a Matrice 100 drone should be done by an experienced person, in adherence with all recommendations and guidelines of the Matrice 100 manufacturer. Before assembling this kit, ensure the Matrice is not powered, has the battery removed, and the rotor blades removed. Failure to follow these instructions can result in injury and/or damage to the Matrice 100 or RedEdge-M.

## Attaching the RedEdge-M and the RedEdge-M Mount

\*NOTE: These instructions assume that the Matrice 100 has a battery bay installed on the bottom of the aircraft main body. The RedEdge-M mount attaches to the bottom of the battery bay.

1. Locate the M3 screws, M3 flat washers, M3 lock washers, and RedEdge-M mount.
2. Attach the mount to the back of the RedEdge-M.
3. The order of washers is important. Starting from the camera, the assembly order should be bracket > flat washer > lock washer > M3 x 5mm screw
4. Next, attach the mount to the Matrice 100 battery cover using the M3 x 6mm screws and internal tooth washers. Hand tighten until snug, then turn an additional ¼ turn.
5. When attached, the camera will be tilted forwards slightly to compensate for the tilt of the aircraft while flying.

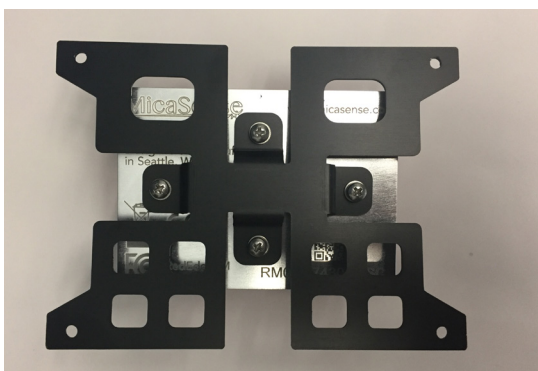

Mounting bracket attached to RedEdge-M

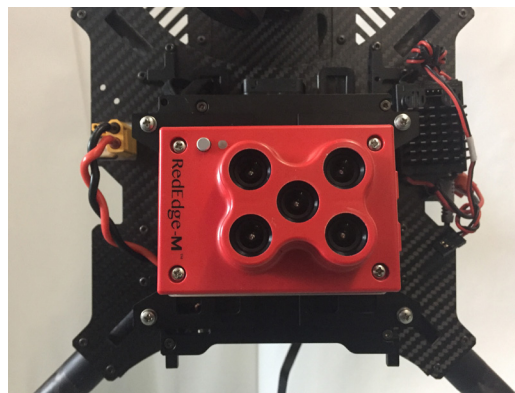

RedEdge-M and mount screwed into Matrice 100 battery cover

## Attaching DLS/GPS mast assembly

1. Locate and remove the DJI mast kit from its packaging.
2. Insert the longest carbon rod into the base mount.
3. Secure the base mount with the included M2 screw
4. Place the top cap on the other side of the carbon rod
5. Secure the top cap on the rod by screwing the M2 screw
6. Screw in the base of the mast assembly into the frame using the provided M2.5 screws and mating cap.

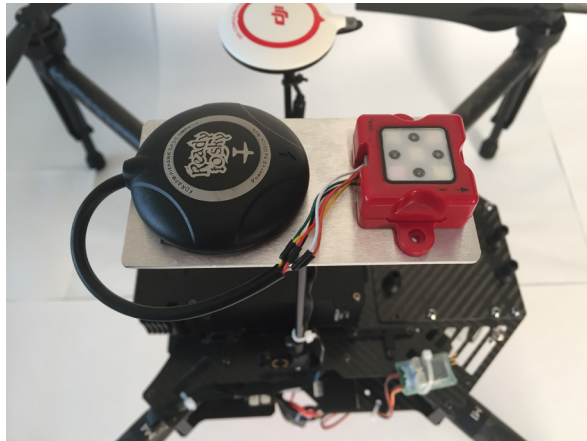

Plate attached to the mast



M2 screw being tightened on mast assembly

7. Using the included alcohol wipe, clean all surfaces where VHB tape will be applied. This is a critical step in promoting adhesion between surfaces.
8. Apply the round double sided tape to the round mast top plate
9. Center the GPS - DLS mounting plate over the round mast plate and firmly press together. Make sure the plate is pointing front-back relative to the aircraft.
10. Using the included VHB tape squares, secure the DLS and GPS to the mounting plate as shown. Make sure the arrows on the DLS and GPS are both pointing forward (toward direction of travel).
11. Plug the GPS wires into the DLS.
12. Connect the long 6pin connector from the DLS "CAM" connector to the matching connector on the RedEdge-M camera.
13. Using the included zip ties, secure the wire to the mast and aircraft frame as necessary.
14. Using scissors or similar, trim the zip ties.



Warning: Failure to properly secure loose wires may lead to interference with the aircraft propellers. This may damage the Matrice 100, RedEdge-M, or both.

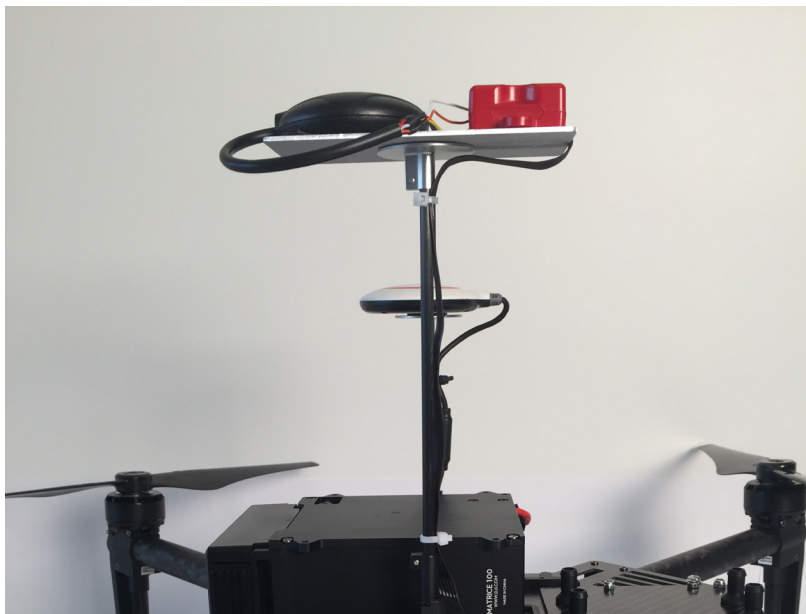

DLS and GPS attached to mounting plate.

# Powering the RedEdge-M

1. Locate the BEC and attach the XT30 connector to the Matrice 100 distribution board as shown below.

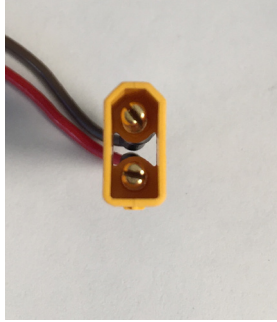

XT30 connector, note gender keying

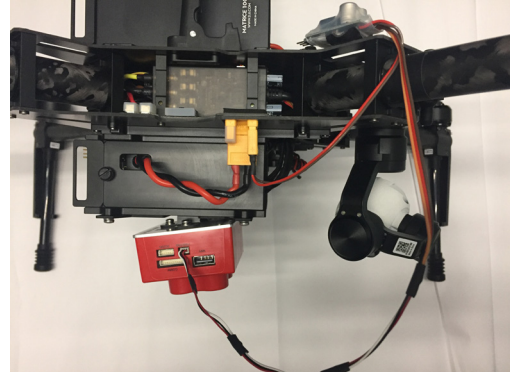

XT30 connector plugged into distribution board

2. Connect the RedEdge-M (3 pin DF13) connector into the power port of the camera.
3. Using VHB tape, secure the BEC to the Matrice 100 frame and secure any loose wires with the provided zip ties.
4. Using scissors or similar, trim the zip ties.

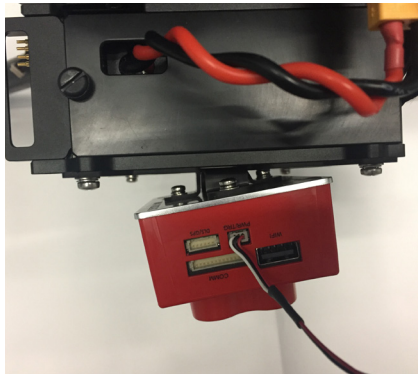

RedEdge-M connector of BEC plugged into RedEdge-M power port

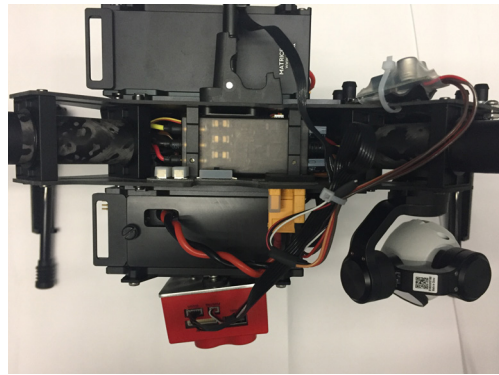

BEC attached to airframe using included VHB tape and zip ties.

For other RedEdge-M associated integration guides, please visit our Knowledge Base at [support.micasense.com](https://support.micasense.com)

For additional questions, please contact [support@micasense.com](mailto:support@micasense.com)

MicaSense RedEdge-M/DJI Matrice 100 Integration Kit Instructions.

The contents of this manual are subject to change without notice.

MicaSense, Inc. assumes no liability for incidental or consequential damages arising from the use of this product, and any claims by a third party.

Copying of the contents of this manual, in whole or in part, as well as the scanner applications is prohibited under the copyright law.

## DISCLAIMER OF WARRANTIES AND LIMITATION OF LIABILITY

MICASENSE MAKES NO REPRESENTATION OR WARRANTY, EXPRESS OR IMPLIED, WITH RESPECT TO MICASENSE ACCESSORIES. MICASENSE DISCLAIMS ANY LIABILITY FOR INDIRECT, CONSEQUENTIAL, PUNITIVE, OR SPECIAL DAMAGES, INCLUDING WITHOUT LIMITATION DAMAGES FOR LOST DATA, LOST REVENUE, LOST PROFITS, OR REPLACEMENT PRODUCT COSTS ARISING OUT OF THE PURCHASE, USE, OR PERFORMANCE OF THE MICASENSE ACCESSORIES, UNDER ANY THEORY OF LIABILITY, EVEN IF MICASENSE HAS BEEN ADVISED OF THE POSSIBILITY OF SUCH DAMAGES. MICASENSE DISCLAIMS ANY IMPLIED WARRANTY OF MERCHANTABILITY OR FITNESS FOR A PARTICULAR PURPOSE, AND DISCLAIMS ANY IMPLIED WARRANTY ARISING FROM A COURSE OF PERFORMANCE, DEALING, USAGE, OR TRADE PRACTICE. THE PRICE OF PRODUCTS DISTRIBUTED BY MICASENSE OR ITS AUTHORIZED DEALERS REFLECTS THE ALLOCATION OF RISK ARISING FROM THE WARRANTY EXCLUSIONS AND THIS DISCLAIMER AND LIMITATION OF LIABILITY.



# It's simple to plan a successful mission



## FLY

The RedEdge-M's low weight, low power requirement, and ability to capture RGB and narrowband spectral bands simultaneously means you can gather the data you need in fewer flights. Have multiple UAVs? RedEdge-M quickly integrates with many different drone platforms.



## PROCESS

With RedEdge-M, you own your data. You're not limited to a particular processing platform. You can choose whichever platform is best for you, your customer, or your project.



## ANALYZE

RedEdge-M has five bands—blue, green, red, red edge, and near-infrared—that our research showed were optimal for sensing crop health. It simply shows you more. And with MicaSense Atlas, you can see many different analytical layers in one easy to use interface, and compare these outputs across time.



## ANYWHERE

We know you need tools you can rely on. That's why we built the sensors we wanted in the field—predictable, tough, and reliable—so you can gather the data you need when you need it.

To learn more about Atlas or to start a free trial, please visit [micasense.com/atlas](https://micasense.com/atlas)

 **SIGN UP**

Visit [atlas.micasense.com](https://atlas.micasense.com) to create your free MicaSense ATLAS account.

 **DOWNLOAD**

Download RedEdge-M user manuals, integration guides and support resources via your ATLAS account.

 **CONTACT**

[support@micasense.com](mailto:support@micasense.com)  
US based MicaSense support is here to help.



Located in Seattle, Washington, MicaSense delivers integrated solutions for data gathering, processing, and analytics across the global agriculture market. With decades of expertise in widely varied UAV applications, the MicaSense team is redefining remote sensing technology and pioneering new ways to collect and analyze information.

MicaSense RedEdge-MDJI Matrice 100 Integration Guide  
Rev 01 – Nov 2017  
P/N: 900-00009