

# MicaSense RedEdge-M™ Multispectral Camera

## Integration Guide



Revision: 02 – November 2017



MicaSense, Inc.  
Seattle, WA

TABLE OF CONTENTS

Introduction and Scope	3
Camera Dimensions and Mass	3
Lens and Imager Information	4
Attachment Points	4
Inputs and Outputs	6
External Power and External Trigger ("PWR/TRG")	6
DLS Module / GPS Module ("DLS/GPS")	9
Serial and Ethernet Data ("COMM")	10
Example Integrations	11
Standalone Integration Using Camera, DLS, GPS Module	11
Integration with Aerial Platform for Triggering	12
Deep Integration with Host Platform	13
Addition of Top of Frame Capture to Integration	14

## 1. Introduction and Scope

This document provides the information required for mechanical and electrical integration of a MicaSense RedEdge-M multispectral camera onto a host aircraft.

## 2. Camera Dimensions and Mass

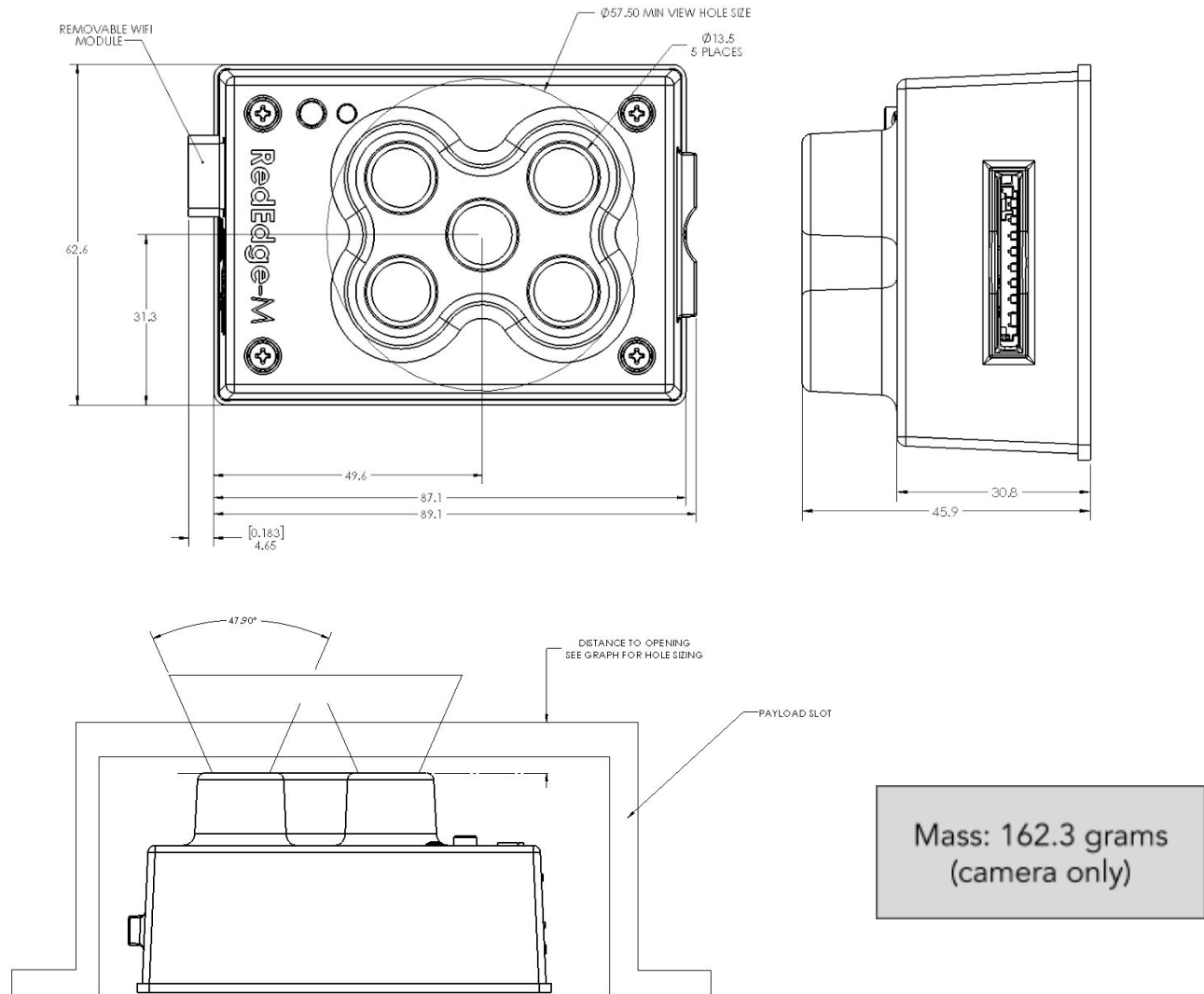

\*All dimensions in mm

### 3. Lens and Imager Information

The imager and lens characteristics are:

Field of View	47.2 deg HFOV (5.4 mm Focal Length)
Aspect Ratio	4:3
Sensor size	4.8 mm x 3.6 mm , 1280 x 960 Global Shutter

### 4. Attachment Points

The RedEdge-M camera can be attached to the host aircraft using at least 2 of the 4 provided threaded mounting points. It is important to use threaded points opposite of each other. M3x0.5 screws are used for this purpose.

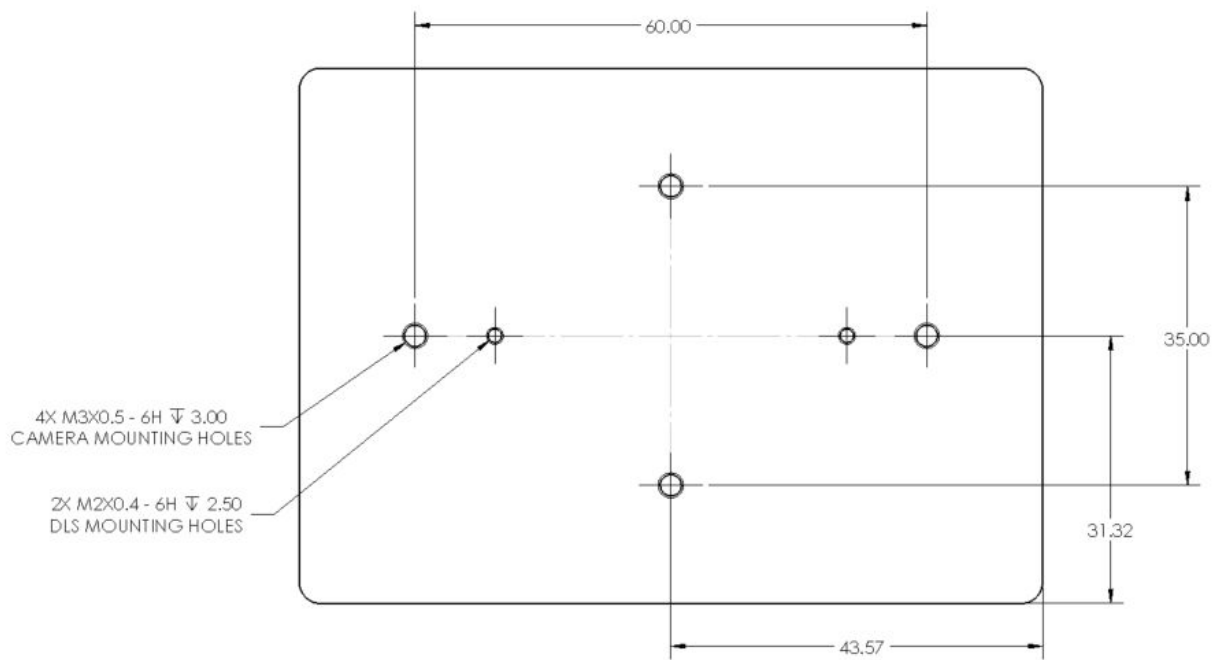

\*All dimensions in mm

**CAUTION**

Do not use a screw that will extend into the threaded holes by more than 3 mm (0.125"). Use a washer or other spacer to ensure that the screws do not go into the camera too far.

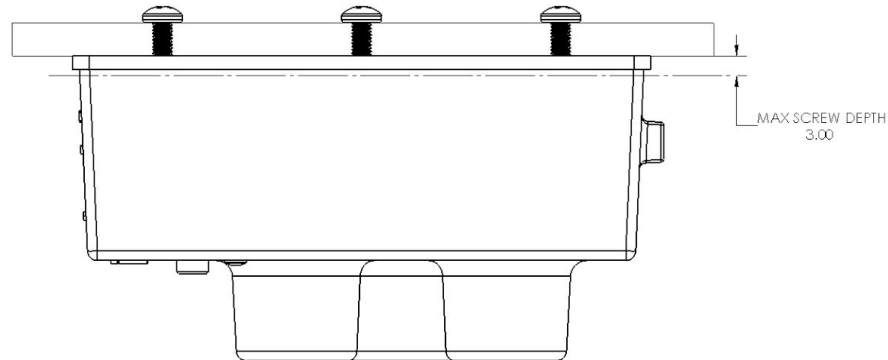

#### NOTE

A very light coating of non-permanent thread locker can be used to prevent the screws from coming loose due to vibration. Wipe off excess thread locker from screw prior to insertion.

### Recommendations for Installation

- The camera should be installed such that it has a clear view of the area directly below the aircraft. The "cone" of the lenses (47.2 degrees total Horizontal Field of View) should be considered in the process of deciding where to mount the camera on the aircraft or payload bay.
- Thanks to global shutter imager technology, the camera is able to withstand some vibration without degrading image quality; nevertheless, vibration isolation between the camera mounting platform and the aircraft is recommended.
- Use of a gimbal is recommended to ensure that the camera is pointing straight down (with respect to the earth) at all times during flight. This gimbal system need only be a "servo-driven" gimbal (for pointing as opposed to high-frequency stabilization). A brushless motor type gimbal (mass-balanced, free-floating) can also be used, but it is not required.
- If the camera's GPS module is used for providing GPS information to the camera, it should be installed in a location of the aircraft where it will have a clear view of the sky. Install the module far away from any devices that could interfere with it (datalink or video transmitters for instance).

## 5. Inputs and Outputs

The RedEdge-M camera features 3 connectors for interface to peripherals and to the host aircraft. A fourth connector (USB Type A) is used for the Wi-Fi module (included).



### 5.1. External Power and External Trigger (“PWR/TRG”)

- Signal definitions and connector

Pin #	Signal
1	Trigger
2	Ground
3	Power
Connector on Camera	Hirose DF13A-3P-1.25H(51)
Mating Connector	Hirose DF13-3S-1.25C 28AWG wire recommended



Pin 1 indicator on DF13 family of connectors (DF13-3S-1.25C shown)

- Power Input

Item	Value
Nominal Voltage	5.0 V DC
Input Voltage Range	4.0V-15.8V DC
Average Power	3.5 Watts average, 8.0 W peak (Camera Not Providing Power to External GPS Module)
	4.0 Watts average, 8.5 W peak (Camera Providing Power to External GPS Module)

- The average power requirement of the RedEdge-M integrated with a DLS and GPS is 4.0W. However, the camera can require instantaneous power of up to 8.0W during operation for brief periods of time. Ensure the power supply can reliably source 8.0W during operation while remaining within the operating voltage range. Operation outside of the specified input voltage range may result in unreliable operation or damage to the camera.
- The RedEdge-M contains under-voltage and over-voltage protection circuitry which nominally applies at 3.8V and 16.0V. However, over the operating temperature range these cutoff voltages can vary by up to 0.2V. For reliable operation, ensure the supply voltage remains within the operating input voltage range at all times over the full range of operating conditions.
- Trigger input: The camera can be triggered either with a rising-edge pulse, falling edge pulse or a PWM signal (such as is typically used with standard servos). When using a PWM signal as the trigger, the camera detects a transition from a "long" PWM to a "short" PWM (or vice-versa depending on the configuration setup of the camera)

Item	Value
Nominal Voltage	3.0 V DC

Voltage Range	0.0 V DC to 5.0 V DC
Absolute Maximum Voltage	5.1 V DC
PWM Trigger Expected Range	1.0 ms to 2.0 ms

**CAUTION**

Care should be taken when multiple “grounds” are used for power and trigger of the camera. Only one ground should be connected to the camera – typically this is the ground that corresponds to the source of the power. If the ground of the trigger signal and the ground of the power source are different, they should not be joined together electrically at the camera. Contact [support@micasense.com](mailto:support@micasense.com) if further information is needed.



## 5.2. DLS Module / GPS Module (“DLS/GPS”)

This connector is used in most integrations to connect to the Downwelling Light Sensor (DLS) and/or GPS module. If both are used, the DLS module is connected directly to the camera, and the GPS module is then connected to the DLS.

This connector also contains two configurable GPIO pins which can be used for camera synchronization with outside systems. Current camera firmware supports a “Top of Frame” signal on pin 4 which can be used to capture the precise moment of image capture to be logged by an external system, such as an RTK or PPK GPS receiver. These configurable IO signals can be used at the same time as the GPS/DLS by splitting the signals out of the cable harness while leaving power, ground, RX, and TX intact for DLS/GPS communications.

- Signal definitions and connector

Pin #	Signal	Direction
1	5.0 V DC Output	Output From Camera
2	DLS/GPS RX	Output From Camera
3	DLS/GPS TX	Input To Camera
4	GPS IO 0 (Configurable)	Input To Camera/Output from Camera
5	GPS IO 1 (Configurable)	Input To Camera/Output from Camera
6	Ground	Ground
Connector on Camera	Hirose DF13A-6P-1.25H(51)	
Mating Connector	Hirose DF13-6S-1.25C 28AWG wire recommended	

When connecting a GPS module to this port, the camera uses the ublox UBX serial protocol for communication back and forth to the GPS using the NAV and RXM data classes; and requires both the GPS RX and GPS TX lines to be connected in order to have two way communications with the DLS and/or GPS.

### 5.3. Serial and Ethernet Data (“COMM”)

This connector is available for tighter integration with host aircraft. It includes a standard TTL-level serial port as well as an Ethernet port. Documentation for the communications protocol is available by contacting MicaSense.

Pin #	Signal	Direction
1	Serial RX (3.3 V)	Output From Camera
2	Serial TX (3.3 V)	Input To Camera
3	Serial Ground	Ground
4	Ethernet RX P (B+)	Output From Camera
5	Ethernet RX N (B-)	Output From Camera
6	Ethernet Line Ground	Ground
7	Ethernet TX P (A+)	Input To Camera
8	Ethernet TX N (A-)	Input To Camera
9	Ethernet RX P 1G (D+)	Output From Camera
10	Ethernet RX N 1G (D-)	Output From Camera
11	Ethernet TX P 1G (C+)	Input To Camera
12	Ethernet TX N 1G (C-)	Input To Camera
Connector on Camera	Hirose DF13A-12P-1.25H(51)	
Mating Connector	Hirose DF13-12S-1.25C 28AWG wire recommended	

## 6. Example Integrations

RedEdge-M is designed for integration into a variety of platforms. Below are some common integration configurations.

### 6.1. Standalone Integration Using Camera, DLS, GPS Module

The standalone integration option requires only that power is provided to the RedEdge-M system. Triggering is configured via the WiFi interface to either "Overlap" or "Timer" mode. GPS information is provided by the included GPS receiver connected to the DLS.

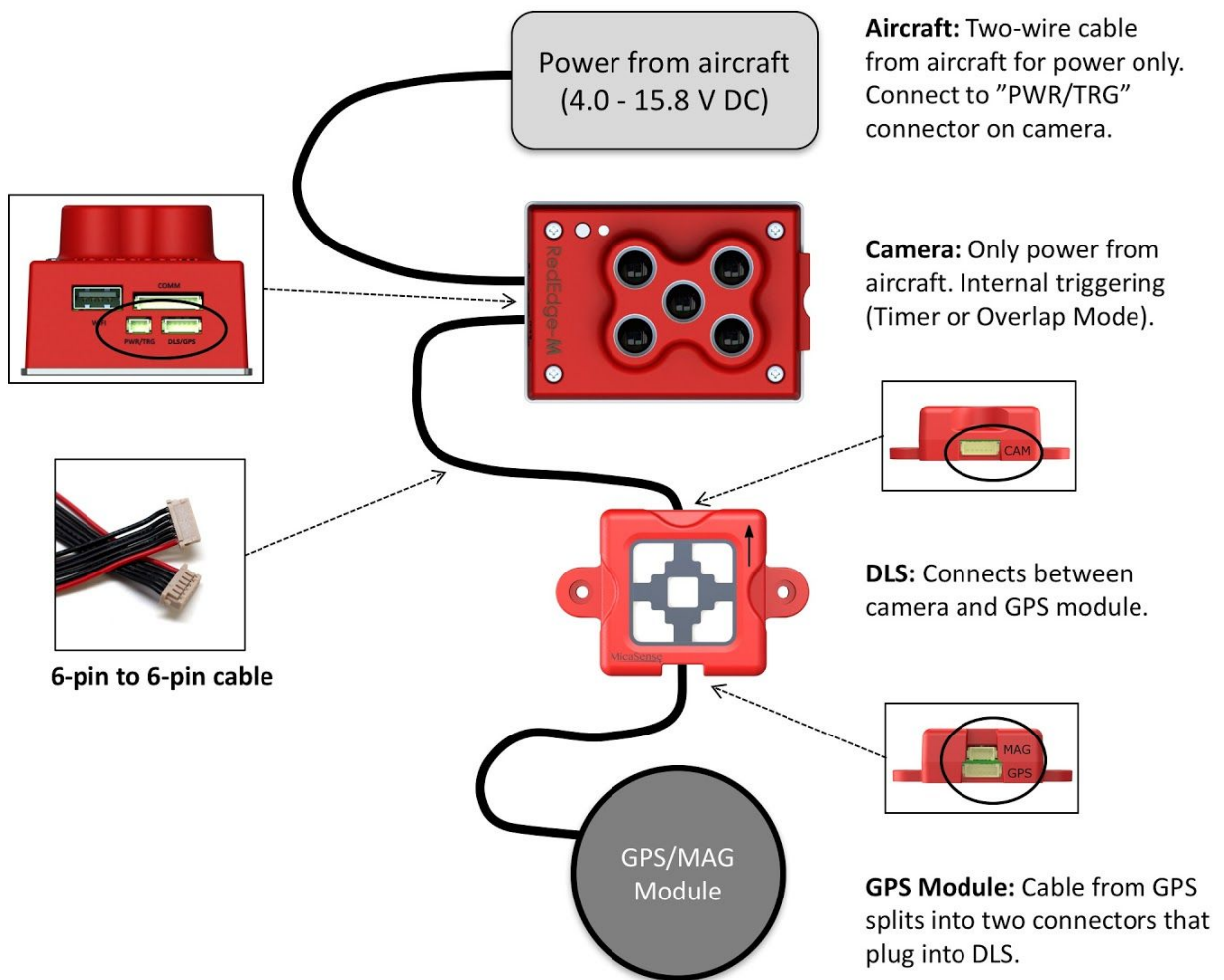

### 6.2. Integration with Aerial Platform for Triggering

Using the RedEdge-M trigger input, the host platform can command image capture at optimal times based on the operation profile. This allows the operation planning to be conducted through the host vehicle mission planning software without the need to configure the camera for operation over WiFi at the start of each operation.

In this integration triggering can be commanded via a rising-edge pulse, falling-edge pulse, or most commonly, using a PWM signal such as a standard servo pulse. When using a servo pulse, RedEdge-M can trigger image captures when the pulse transitions from short to long (e.g. 1.0ms to 2.0ms) or long to short (e.g. 2.0ms to 1.0ms). These trigger settings are configurable via the WiFi interface, and are persistent once saved.

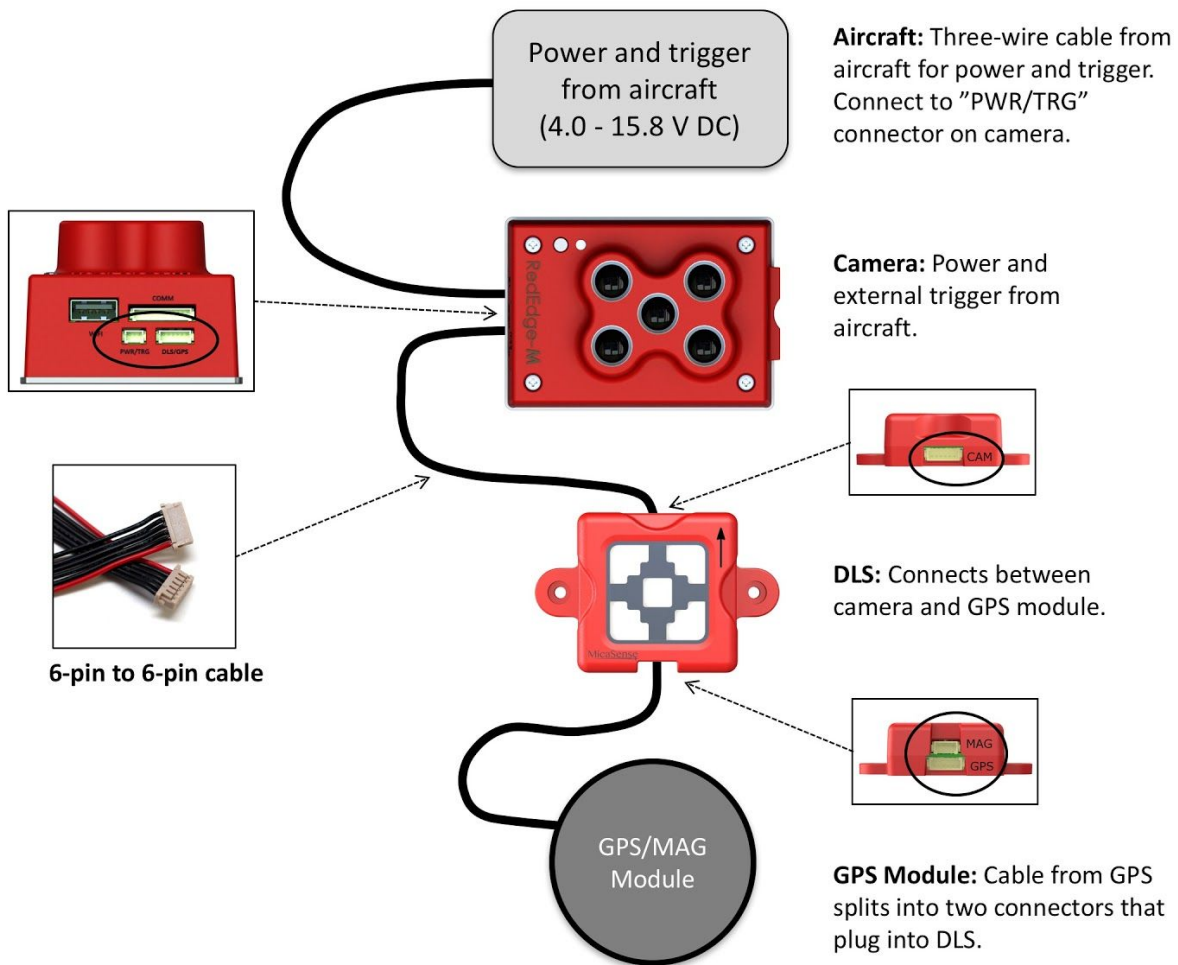

### 6.3. Deep Integration with Host Platform

The RedEdge-M supports deep integration with host platforms allowing the replacement of the included GPS receiver with host-provided GPS information. In this mode, GPS location, altitude, and time, as well as platform orientation information is provided via the host serial or Ethernet interface. Host integration through serial connection is accomplished through MAVLink messaging and is compatible with common autopilot systems such as Pixhawk and APM. Deep integration in this manner is best performed by integrators with a strong working knowledge of the MAVLink communication protocol, serial communications, and advanced Pixhawk or APM configuration. Ethernet connectivity is also an option - visit [support.micasense.com](http://support.micasense.com) for further resources on either of these two protocols.

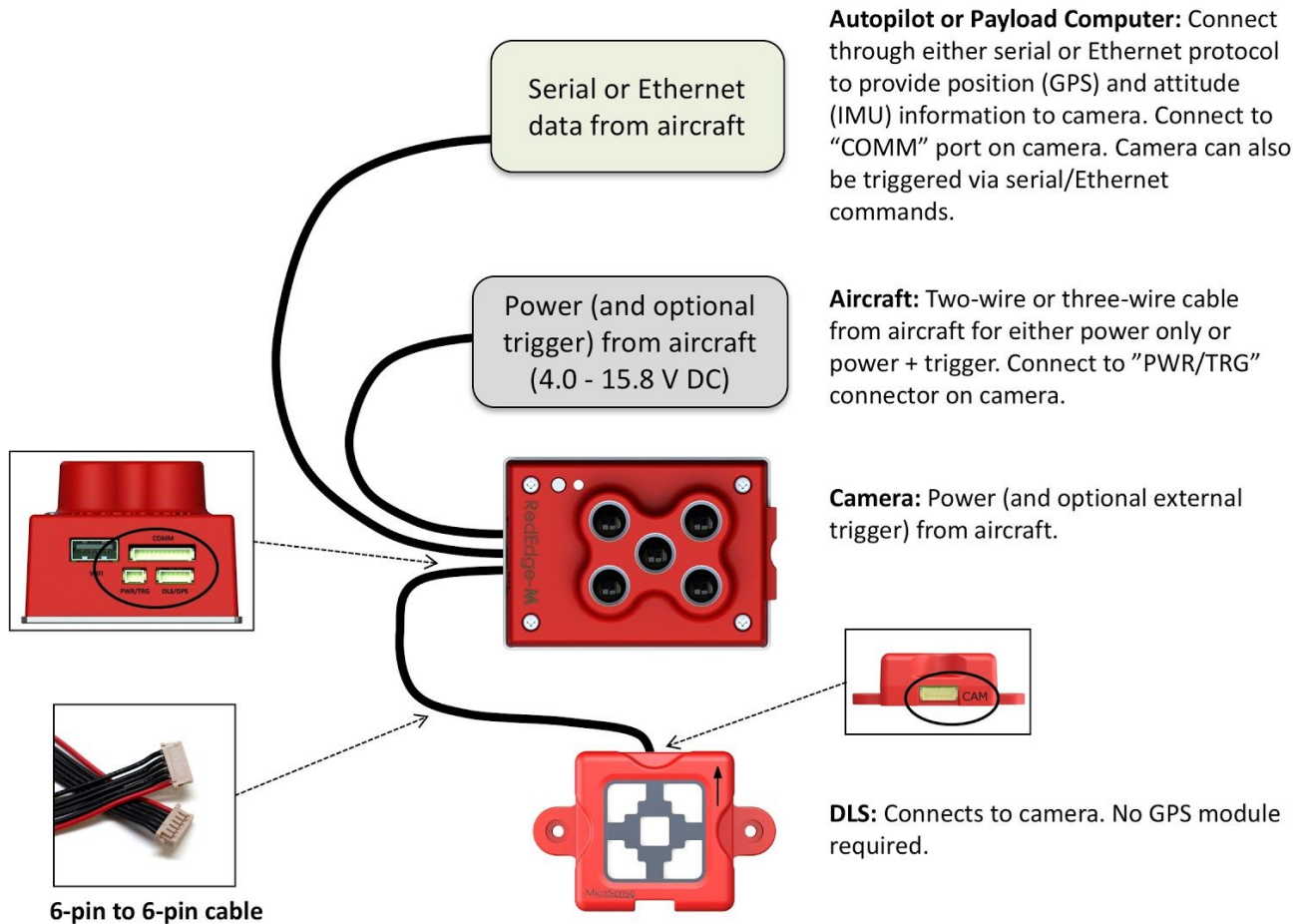

6.4. Addition of Top of Frame Capture to Integration

For integration with RTK and/or PPK GPS systems, or other systems requiring precision timestamping of image capture, the Top of Frame output (ToF) can be used to precisely log the start of image exposure with an accuracy of a few tens of nanoseconds. The ToF function is available for use in any of the integration scenarios listed above, though typically the aircraft will be providing both triggering as well as GPS/IMU information to the camera via serial/Ethernet protocol.

To use RTK/PPK GPS with sync output from camera, a custom 6-pin cable will be needed, which connects to the "DLS/GPS" connector on the camera. One end of the cable will connect to the DLS and the other end (with Ground and Pin 4 - see table in Section 5.1.2) would connect to the RTK/PPK GPS receiver or associated computer.

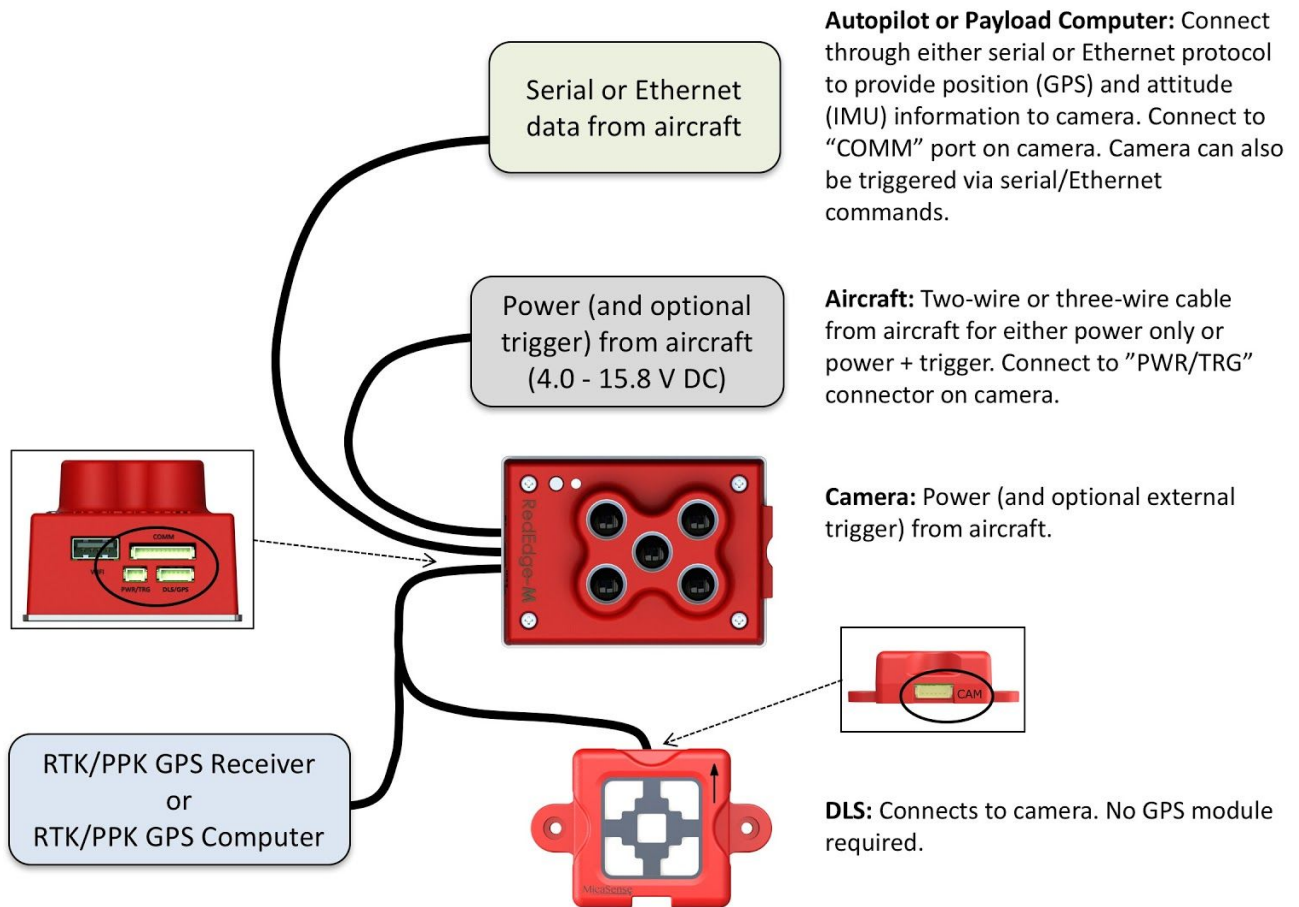

---

MicaSense RedEdge-M™ Multispectral Camera  
Integration Guide  
Rev 02 – November 2017

MicaSense, Inc.  
Seattle WA 98103

---

- The contents of this guide are subject to change without notice
- MicaSense, Inc. assumes no liability for incidental or consequential damages arising from the use of this product, and any claims by a third party.
- Copying of the contents of this guide, in whole or in part is prohibited under the copyright law.





